

VARIOVISION

Welding camera system WVS-55

By semi-automatic or automatic welding equipment the service and control of the welding torch mostly occurs from a control station. To set the position of the welding torch and the parameters for the welding process optimally, however, a visual inspection from the control station is required.

The welding camera WVS-55 provides a sharp B/W picture and allows therefore an optimal observation of welding torch, filler wire and work piece as well as welding arc and melting area. This can help you e.g., to shorten the set-up time substantially or faster recognition of possible welding mistakes.

The camera cables can be ordered up to 50 m length. With it, e.g., the camera can be controlled by a remote control station or a complex cable transfer in the machine can be carried out.



*Picture shows camera and optional cooling plate

Version 1.4.2

Table of content

Reference.....	3
Safety instructions.....	4
The welding vision system consists of.....	5
Installation.....	5

Reference

Unfortunately there is no guarantee, that this manual is without lacking.
Changes could be made without announcements.

Note the scope of delivery and check if all ordered parts are delivered

Due to customers order, additional components can be delivered.

If components are missing please contact your dealer.

Never try to repair a broken system by yourself, contact your dealer.

Warranty will lost by inappropriate use of the system!

Safety instructions

Please read this manual carefully and check for the instruction before operating the WVS-55 welding vision system.

Keep these instructions at a safe place.

Use the system only in the specified temperature and air humidity area.

Use only original power supplies for operating the system.

Do not open the case of the camera. Parts inside can be damaged or de-adjusted.

Get sure, that the power supply is disconnected, when system will be installed and cables will be connected.

Connection cables should be moved in such a way that no one can step on it or that they can be damaged by falling down objects.

Never pour liquids about the camera or the operating device.

Never put objects by openings of the machine. You can touch voltage-carrying shares and receive an electric blow.

Before cleaning the system has to go is switched off and is separated from the operating voltage. Use to the cleaning a humid cloth.

Use no sharp cleaning agents or spray cans.

With operational disturbances switch off the system and separate it from the main power. To leave servicing works or repair work exclusively to the manufacturer.

The installation of the system may be carried out only by certified staff and must correspond to the local regulations.

The welding vision system consists of

- CMOS video camera
- lens as specified by customer
- Iris and IR-filter
- camera cable with cable distribution box, depending on the order, up to 50 m long
- power supply

Monitor cable and Monitor has to be ordered separately

Installation

- Connect all cables before connecting the main power supply
- At the assembly (mounting) of the camera is to be noted that the camera is set in correct distance to the object (melting area). This distance is to be kept - otherwise a sharp position adjustment of the object is not guaranteed.
- Loose lock screw on lens and turn lens until a sharp picture appears on monitor.
- Due to high temperatures near camera please take care for proper cooling.

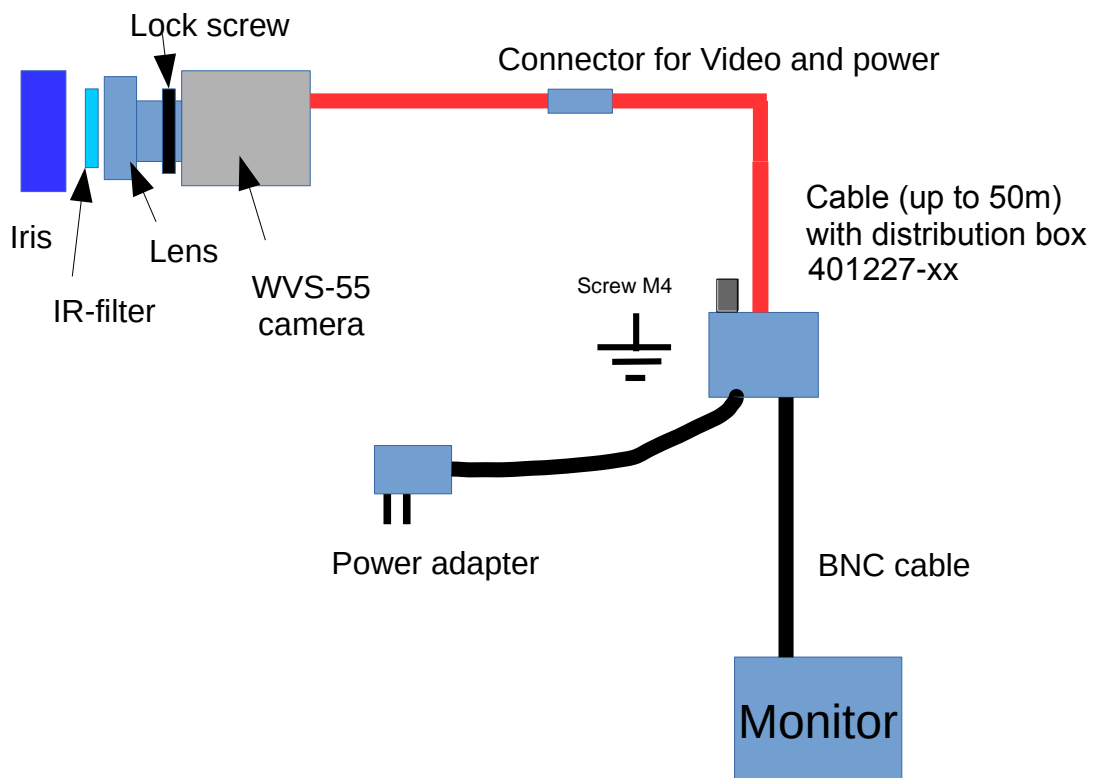

Technical Data:

Sensor: 1/3" -CMOS, monochrome,
PAL-Standard, 768 x 576 Pixel

Lenses: different, fixed focal length
M12 – S-mount

Spectral range: 450 nm - 1050 nm

Frame rate: 25 fps @ 768 x 576 (interlaced)

Video output: TV Composite Video

Power supply: 12 VDC, power supply unit 100 – 240 VAC

Operating temperature: 0...50 ° C

Dimensions: Camera 20 x 20 x 18 mm
(W x H x D)

Weight: Camera approx. 130 g

Power supply:

Description:	Art.-No.:	
Wall Power Supply Euro	402501	100 – 240 VAC to 12VDC
Wall Power Supply Euro	402502	100 – 240 VAC to 12VDC, if cable length > 40m

Connection cable:

Description:	Art.-No.:	
Cable with splitter box	401277-xx	xx = according cable length

Options:

Description:	Art.-No.:
Mounting Plate	401435-B, or
Cooling Plate	402602-B



Variovision Thomas Stelzl
Pöttinger Straße 23
DE-82041 Oberhaching

Tel. +49 89 23967195
Fax +49 89 23967196
www.variovision.tv
info@variovision.tv
www.weldingcamera.com